

## GEL COAT TROUBLESHOOTING GUIDE, continued

6. Discoloration On Finished Parts: This problem is caused from porosity related to air entrapment while spraying. This can be overcome by spraying the mold surface with several light passes. It is also important to bleed any moisture from the air lines and to be sure that the mold surface is dry.

7. Craters And Pock Marks: These surface blemishes can be caused by improper resin to catalyst ratios and improper air pressure both high and low. Another cause for craters would be oil or moisture on the surface of the mold.

8. Fisheyes: Fisheyes are usually caused by contaminants on the mold like dirt, moisture or oils. Bleeding the air lines and using air filters will lower any air related contaminants. Try to isolate the spray area from any oils, especially silicones.

9. Blisters When Immersed In Water: Blisters can be caused for the following reasons:

1. Incomplete cure
2. Improper wetting of the back up fibers
3. Bad bond between the gel coat and the back up laminate. This is often caused by contamination.
4. Thin gel coat

10. Lifting Of Gel Coat Before Laminating: This condition is usually related to shrinkage of the gel coat. Shrinkage can be caused by:

1. Too fast of a curing time normally caused by over-catalyzation.
2. Delays between the gel coat and laminating can cause shrinking
3. Variations in gel coat thickness can vary the gel time which can cause shrinkage.
4. The mold surface is too hot.

11. Back Up Pattern Showing Through Gel Coat: This visual pattern is caused by too low a gel coat thickness or the gel coat was not properly cured.

12. Gel Coat Sticking To The Part: This condition is caused by improper releasing of the mold surface. It is important to use release agents formulated for the reinforced plastics industry. Proper training and common sense will eliminate most of the problems associated with gel coats. Proper handling of gel coats will result in a part with a blemish free surface.

# 1/4 Pint Touch Up Spray Gun 123-A

## Usage Instructions & Parts List



## Operating Instructions and Suggestions

This portable touch-up gun offers a highly controlled spray pattern for pinpoint accuracy, reducing wasted gel coat and harmful emissions. Its small size, minimal air consumption, and easy clean-up makes it the perfect choice for on-site repairs.

This gun comes fitted with a 2.0mm nozzle, which is ideal for any of our gel coats. But don't use it just for repairs; it's also great for spraying PVA! Ships complete with 1/4 pint cup, cleaning brush, and 1 mini filter.

Read this Instruction Manual carefully. Basic precautions should be strictly followed to prevent the damage to the tool and injury to the operator. Retain this manual for further reference.

### Important Safety Instructions:

1. Certain materials can create toxic vapors, intoxication and serious damage to health. Always wear safety glasses, gloves and respirator to prevent the toxic vapor hazard, or solvent and gel coat coming into contact with your eyes or skin.
2. Never use oxygen, combustible or any other bottle gas as a power source to avoid explosion and serious personal injury.
3. Fluid and solvent can be highly flammable or combustible. Use in well-ventilated spray booth and avoid any ignition sources, such as smoking, open flames and sparks.
4. Disconnect tool from air supply when not in use or maintaining also a shut off valve. As an emergency stop is recommend.
5. Use clean, dry and regulated compressed air rated at 30 - 80 PSI. Never exceed maximum permissive operating pressure.
6. Never use homogenate hydrocarbon solvent, which can chemically react with aluminum and zinc parts and chemically compatible with aluminum and zinc parts.
7. Never point gun at you or others at any time.
8. Before operating the tool, make sure all the screws & caps are securely tightened in case of leaking.
9. Before spraying, be sure the trigger and related parts operate smoothly.
10. Never modify this tool for any applications. Only use recommended parts, nozzles and accessories.

## GEL COAT TROUBLESHOOTING GUIDE

Proper gel coat application is difficult for professionals and is probably the most common problem area for those new to fiberglass work. Most common gel coat problems are related to temperature variation, catalyzation and a variety of handling techniques. The following list of gel coat problems and causes should help to resolve some of the difficulties associated with gel coat.

1. Wrinkles And Pinholes: A coating less than five mils thick may wrinkle, especially when brush marks are present. Check the thickness using a gel coat thickness gauge. The preferred thickness is .010" to .020".

A wrinkle can also occur if the gel coat is not cured enough prior to lay-up. Before lay-up check the surface for tack. The surface should be sticky but not transfer to your finger. Several things can affect a slow cure; solvent or water entrapment, under catalyzation, cold temperatures and other factors.

If the gel coat film contains pinholes, check the spray equipment for moisture in the air lines or dirt in the traps. It is also important to review your spray techniques.

2. Slow Gel Coat Cure: Any temperature below 70 degrees F will retard the gel time. An under-catalyzed gel coat will also result in a slow cure but this is not a recommended technique for deliberately lengthening gel time. High moisture and humidity will lengthen the gel time.

3. Sagging Of The Gel Coat: The most common reasons for gel coat sags would be when the gel coat is applied in an excessively heavy application in one or more passes.

To avoid sagging, spray in multiple light coats at a 15" distance from the mold. The maximum thickness to be sprayed at one application is .016".

4. Porosity: Gel coat porosity (air bubbles) is normally caused by trapped air or moisture. This can be prevented by limiting the spray thickness per pass to .005". It is also important to verify that the proper air pressure is being used because an over pressurized spray can cause fine porosity. Air pressure should be set at 30 - 80 PSI, depending on viscosity.

5. Separation Of Color: Most color separations are related to improper spray techniques. Reduce or lower thinning agents and lower the per pass thickness of the gel coat. It is also important to avoid any spray overlap areas.

## Troubleshooting

Symptom	Problems	Solution
Fluttering or spitting	Material in container is low.	Add material into container.
	Dry or worn needle packing set.	Lubricate or replace needle packing set.
	Fluid nozzle loose or worn	Tighten or replace fluid nozzle.
Pattern is arc.	Worn or loose fluid nozzle.	Tighten or replace fluid nozzle.
	Material build-up on air cap.	Remove obstructions from holes, but don't use metal objects to clean it
Pattern is not evenly spread.	Material build-up on air cap.	Clean or replace air cap.
	Fluid nozzle dirty or worn.	Clean or replace fluid nozzle.
The center of Pattern too narrow.	Material too thin or not enough.	Regulate material viscosity.
	Atomization air pressure too high.	Reduce air pressure.
Pattern width of fan-shape is not enough.	Material too thick.	Regulate material viscosity.
	Atomization air pressure too low.	Increase air pressure.

## Features:

	123-A
Feed Type	Gravity
Standard Diameter of Nozzle	2.0mm
Recommended air pressure	2.5 - 3.5 bar (30 - 80 PSI)
Material Capacity	.25 pint
Compressor Required	1 H.P.
Air Consumption	160 – 300 liters per minute
Air Connection	1/4 inch n.p.t.

## Operating Instructions:

- This tool operates on clean, dry, compressed air at regulated pressure at 30 - 80 PSI. Too low or too high pressure will adversely affect the gun and the quality of spray.
- Check and replace any damaged or worn parts on the tool. Make sure the trigger and nozzle can operate well.
- Connect the gun to air supply. Be sure fluid cap, container and air hose should be connected tightly with spray gun.
- When spraying, hold the gun perpendicular to spraying area, and then move it parallel several times. The trigger should be locked before the stroke ended. Keep the appropriate distance of 6-10 inches between gun and surface area, according to the atomization pressure and spraying conditions.

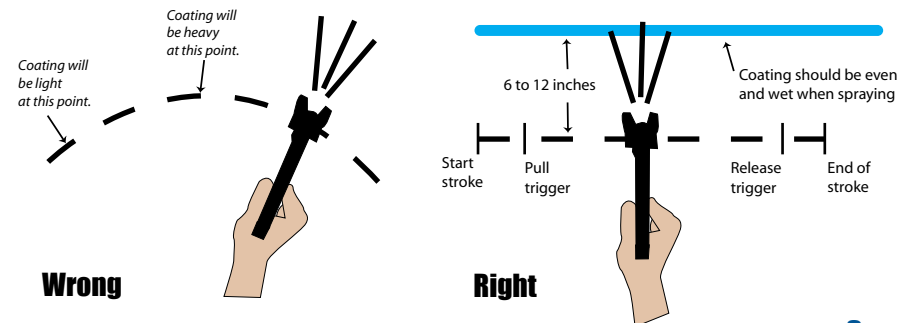

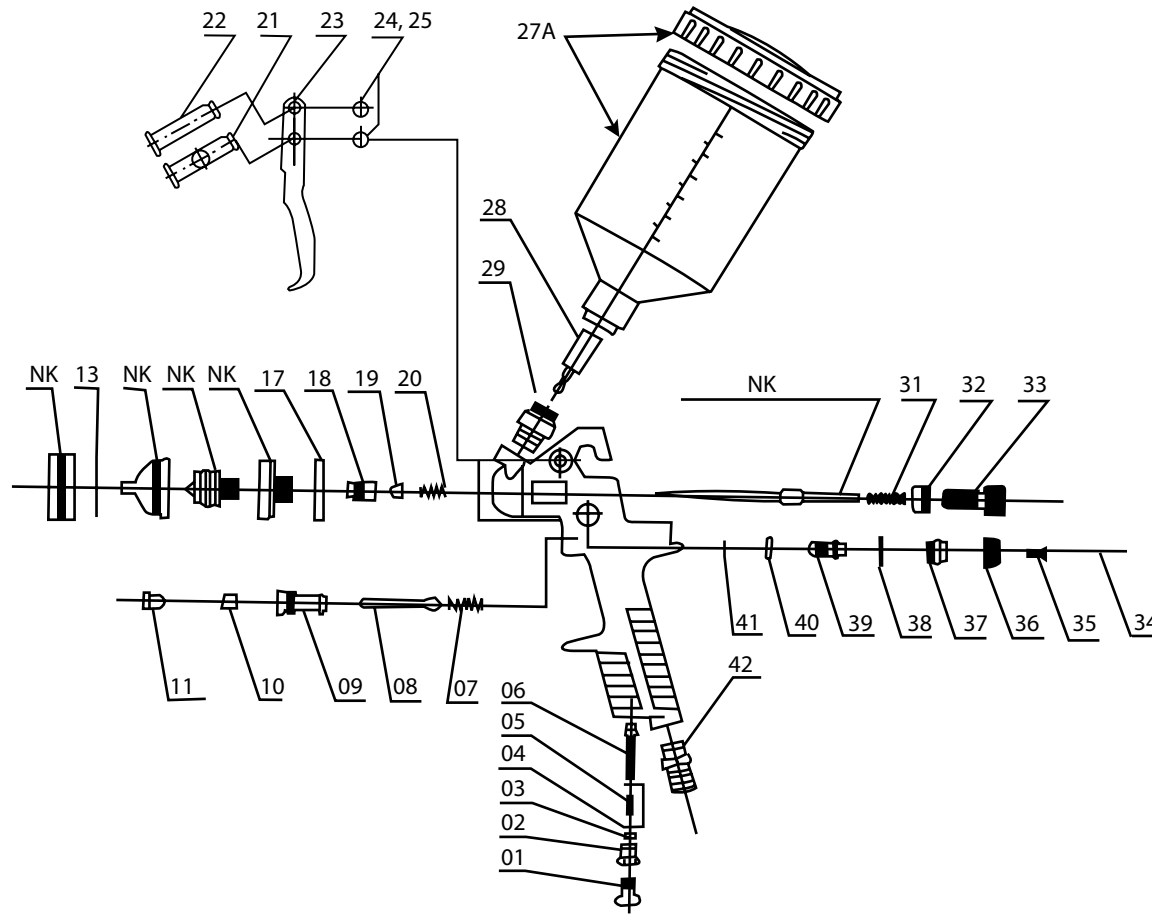

01	Air Adj Screw	11	Lock Screw	25	Snap Retainer	35	Pattern Adj. Knob
02	Air Adj Nut	13	Air Cap O-Ring	27A	Alum Cup Assy. (.30L)	36	Pattern Adj. Screw
03	O ring	17	Fluid Nozzle Washer	27P	Plastic Cup Assy. (.012L)	37	O-Ring
04	Washer	18	Bolt	28	Filter	38	O-Ring
05	Air Valve Spring	19	Needle Washer	29	Fluid Inlet Joint	39	Snap Retainer
06	Air Inlet Valve	20	Compressed Spring	30	Fluid Needle	40	Pattern Adjustment Joint
07	Switch Spring	21	Trigger Lever	31	Fluid Inlet Spring	41	O-Ring
08	Air Inlet Valve Assly	22	Trigger Lever II	32	Mat. Adj. Stop	42	Air Inlet Joint
09	Switch Knob	23	Trigger	33	Mat. Adj. Knob	NK20	2.0mm Nozzle Kit
10	Switch Washer 2 (Req.)	24	Snap Retainer	34	Phillips Screw	NK12	1.2mm Nozzle Kit
						NK10	1.0mm Nozzle Kit
						NK08	0.8mm Nozzle Kit